

CU-E20, E22

**E65C**

User Manual

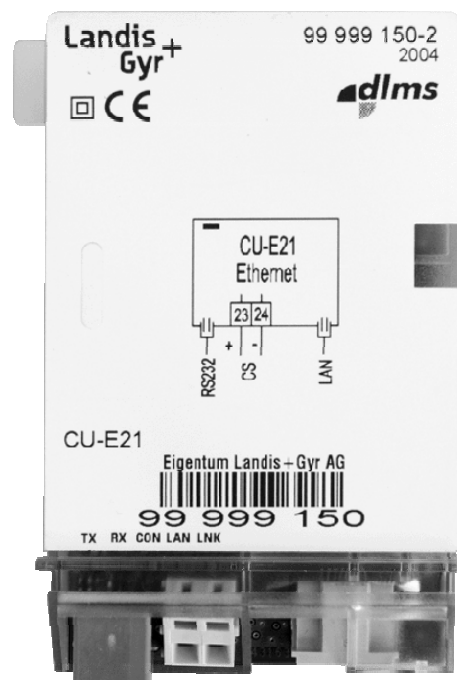

E65C CU-E20, E22 communication units provide Ethernet communication between E650 or E850 meters and a central system.

Date: 06.11.2009

Filename: H 71 0200 0316 en - CU-E2x - User Manual.docx

© 2009 Landis+Gyr AG

# Revision History

Version	Date	Comments
a	19.10.2004	First edition
b	16.04.2009	New RS485 installation note
c	12.10.2009	Market name change and E21 discontinuation
d	06.11.2009	Revision of entire document (layout, wording)
e	05.01.2010	Document number correction

Copyright © 2009, Landis+Gyr. All rights reserved. Subject to change without notice.

**Landis+Gyr AG**  
Feldstrasse 1  
CH-6301 Zug  
Switzerland  
Phone: +41 41 935 6000  
[www.landisgyr.com](http://www.landisgyr.com)

# About this Document

<b>Range of validity</b>	The present user manual applies to communication units E65C CU-E20 and CU-E22 – designated CU-E2x below.
<b>Purpose</b>	<p>This user manual supplements the operating instructions of the meter and of the CU-adapter E65C CU-ADP1 and is incomplete without the data contained therein. Together with these operating instructions, the user manual contains all the information necessary for the operation of the CU-E2x communication unit for the intended purpose. This includes:</p> <ul style="list-style-type: none"><li>• Provision of knowledge concerning characteristics, construction and function of the communication unit CU-E2x</li><li>• Information about possible dangers, their consequences and measures to prevent any danger</li><li>• Details concerning the performance of all work throughout the service life of the communication unit CU-E2x (installation, commissioning, operation, maintenance, shutting down and disposal)</li></ul>
<b>Target group</b>	The contents of this user manual are intended for technically qualified personnel of energy supply companies responsible for the system planning, installation and commissioning, operation, maintenance, decommissioning and disposal of the meters.
<b>Reference documents</b>	<p>The technical data and the functional description of the communication unit CU-E2x can be found in the following documents:</p> <ul style="list-style-type: none"><li>• H 71 0200 0320 en "Technical Data E65C CU-E20, E22"</li><li>• H 71 0200 0321 en "Functional Description E65C CU A, B, M, G, D, P, E, Q"</li><li>• H 71 0200 0323 en "User Manual E65C CU-ADP1"</li></ul>

# Table of Contents

<b>1</b>	<b>Description of Unit</b>	<b>5</b>
1.1	Scope of Application	5
1.2	Characteristics	5
1.3	Type Designation	5
1.4	Functions	6
1.4.1	Ethernet Interface	6
1.4.2	CS-Interface	6
1.4.3	RS485-Interface	6
<b>2</b>	<b>Safety</b>	<b>7</b>
2.1	Safety Information	7
2.2	Responsibilities	7
2.3	Safety Regulations	8
<b>3</b>	<b>Mechanical Construction</b>	<b>9</b>
3.1	Overview	9
3.2	Interface Connections	10
3.2.1	Connections CU-E20	10
3.2.2	Connections CU-E22	11
3.3	Faceplate	12
3.4	LEDs	12
<b>4</b>	<b>Installation/De-installation</b>	<b>13</b>
4.1	Fitting in Meter	13
4.2	Fitting in CU-Adapter CU-ADP1	14
4.3	Connecting the Communication Unit	15
4.3.1	Connecting the Ethernet Interface	15
4.3.2	Connecting the CS-Interface	15
4.3.3	Connecting the RS485-Interface	17
4.3.4	Final Operations	17
4.4	Commissioning and Functional Check	17
4.5	Removal/Exchange of Communication Unit	17
<b>5</b>	<b>Operation</b>	<b>18</b>
<b>6</b>	<b>Service</b>	<b>19</b>
6.1	Troubleshooting	19
6.2	Repairing the Communication Unit	19
<b>7</b>	<b>Maintenance</b>	<b>20</b>
<b>8</b>	<b>Disposal</b>	<b>21</b>
<b>9</b>	<b>Index</b>	<b>22</b>

# 1 Description of Unit

## 1.1 Scope of Application

The communication unit CU-E2x can be fitted in and removed from the following Landis+Gyr meters without opening the calibration seal:

- Landis+Gyr E650 ZxD300/400xT industrial and commercial meters
- Landis+Gyr E850 ZxQ high-precision meters

Inserted in a CU-adapter CU-ADP1, the communication unit CU-E22 can also be used with other meters (e.g. Landis+Gyr E650 ZxD300/400xR, ZMD100AR, ZxB or meters from other manufacturers). Connection to the meter is made in this case via an interface in the communication unit (CS or RS485).

## 1.2 Characteristics

The communication unit CU-E2x always contains a built-in Ethernet interface and depending on version an RS485 and a CS interface (CU-E22). It is used to supplement the meters listed above.

The Ethernet interface serves to read out or re-parameterize the meter from a central station with a LAN via the Internet.

The RS485 and CS interfaces can be used for the connection of meters separated by greater distances (multiple connections). The CS interface can be parameterized as active or passive interface, so that it can be used as master or slave as required with multiple connections.

With external application of the communication unit CU-E22 in a CU adapter one of the existing interfaces of the communication unit is required for connection to the meter.

## 1.3 Type Designation

The type designation of the communication unit CU-E2x is added to that of the meter (see meter user manual), but is not shown on the main faceplate of the meter. It is specified directly on the case of the communication unit and can be seen through the front door of the meter through an opening on the tariff faceplate.

The communication unit CU-E2x is available in the following versions:

Type	Ethernet	RS485	CS+
CU-E20	●		
CU-E22	●	●	●

## 1.4 Functions

A functional description of the communication unit CU-E2x is provided separately. The following main functions are briefly summarised below.

### 1.4.1 Ethernet Interface

The Ethernet interface is standardised to IEEE 802.3. This is a standard for data transmission in packet form in LAN networks (Local Area Network). The Ethernet interface permits connection to the LAN by means of the transmission control protocol TCP/IP (Transmission Control Protocol/Internet Protocol). The maximum transmission speed is 10 Mbps.

### 1.4.2 CS-Interface

The serial bi-directional CS-interface is standardised to IEC 62056-21 or DIN 66258. It supports both the communication protocol to IEC 62056-21 as well as communication according to dlms and can be operated both actively and passively.

### 1.4.3 RS485-Interface

The serial bi-directional RS485-interface is standardised to ISO-8482. It is basically intended for the connection of several meters (up to 31) via a master to a communication path and therefore to read out the meter data or to perform service functions (such as setting of start values, time/date, etc.).

## 2 Safety

### 2.1 Safety Information

In this manual, attention is drawn to dangers with symbols, reflecting the danger level, i.e. the severity and probability of any danger, as follows:

**Definition of Danger**

For a possibly dangerous situation, which could result in severe physical injury or fatality.

---

**Definition of Warning**

For a possibly dangerous situation, which could result in minor physical injury or material damage.

---

**Definition of Note**

For general details and other useful information to simplify the work.

---

In addition to the danger level, safety information also describes the type and source of the danger, its possible consequences and measures to counteract the danger.

### 2.2 Responsibilities

The owner of the communication units is responsible that all persons engaged on work with the communication units:

- Are competent and qualified in accordance with national regulations (see ISSA "Guideline for Assessing the Competence of Electrically Skilled Persons").
- Have read and understood the relevant sections of the user manual.
- Strictly observe the safety regulations (according to the following section) and the instructions in the individual chapters.

The owner of the communication units is also responsible for:

- The protection of persons.
- The prevention of material damage.
- The training of personnel.

Landis+Gyr AG provides training courses for this purpose on specific equipment; please contact the relevant agent if interested.

## 2.3 Safety Regulations

The following safety regulations must be observed at all times:

- Changing of the communication unit must only be made on meters not under voltage.
- Devices which have fallen down should not be installed, even if no damage is apparent, and should be returned for testing to an authorised service centre (internal damage possible).
- Communication units must never be cleaned with running water or high pressure devices. Water can cause short-circuits or damage el. components.

Note also the safety instructions given in the user handbooks for the meter and the CU-adaptor CU-ADP1 as far as they are relevant to the communication units.



## 3 Mechanical Construction

### 3.1 Overview

The communication unit CU-E2x is a unit complete in itself with its own plastic case.

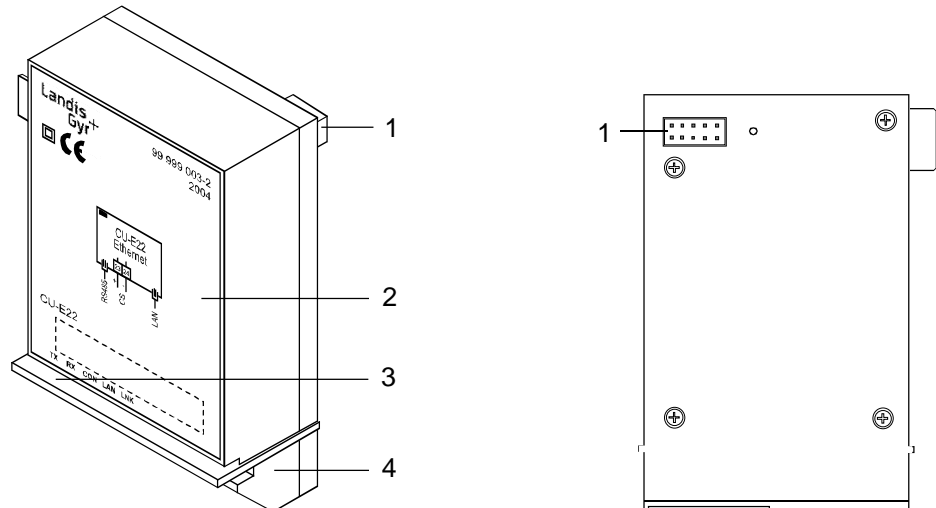

Fig. 3.1 Communication unit CU-E2x, removed

- 1 10-pin connector
- 2 Faceplate
- 3 Transparent strip through which the LEDs are visible
- 4 Interface connections

The faceplate of the communication unit fitted in the meter is visible with the meter front door open. When fitted in a CU-adapter, the faceplate can be seen through the transparent front cover.

The interface connections are situated underneath, while a 10-pin connecting plug provides connection at the rear with the meter electronics or CU-adapter.

Five LEDs on the circuit card optically indicate through the transparent strip under the face plate transmission and reception activities.

The communication unit has no seal of its own. It is secured when built-in by a utility seal of the meter or CU-adapter.

## 3.2 Interface Connections

The Ethernet connection of the communication unit CU-E2x is made via an RJ45 socket with the following pin assignment:

Pin No.	Terminal	Signal
1	TxD+	Transmitted Data +
2	TxD-	Transmitted Data -
3	RxD+	Received Data +
6	RxD-	Received Data -

The pins of the RJ45 socket are numbered as follows:

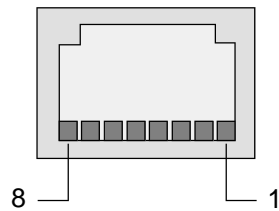

Fig. 3.2 Pin numbering of RJ45 socket

The pins of the RJ12 socket are numbered as follows:

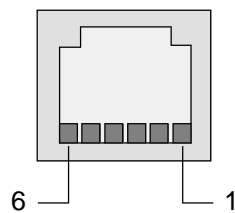

Fig. 3.3 Pin numbering of RJ12 socket

### 3.2.1 Connections CU-E20

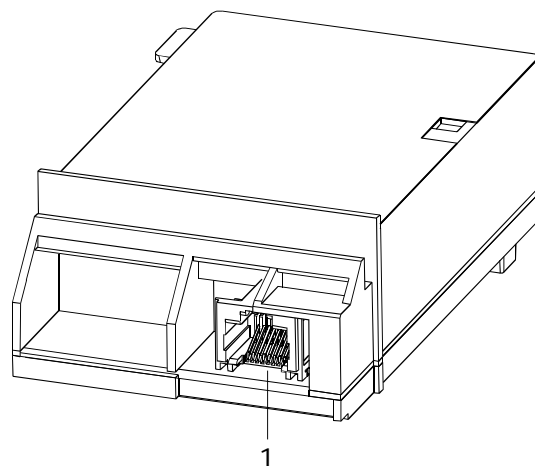

Fig. 3.4 Connections CU-E20

1 Ethernet interface (RJ45 socket)

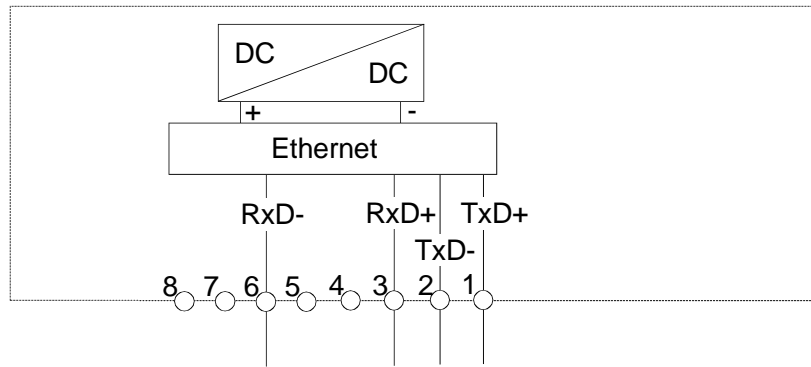

Fig. 3.5 Connection diagram communication unit CU-E20

### 3.2.2 Connections CU-E22

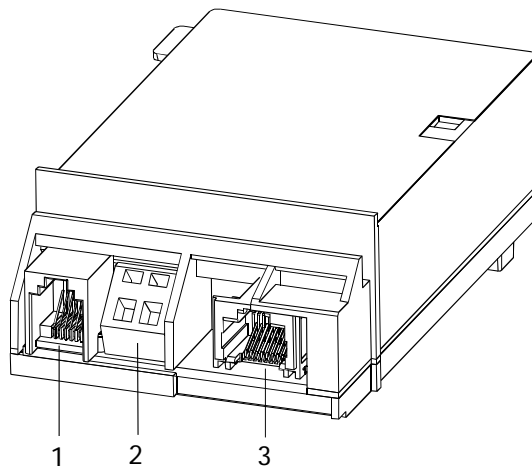

Fig. 3.6 Connections CU-E22

- 1 RS485 interface (RJ12 socket)
- 2 CS interface (screwless spring-type terminals WAGO)
- 3 Ethernet interface (RJ45 socket)

With the screwless spring-loaded terminals of the CS interface the polarities are determined as follows:

- + left terminal (23)
- right terminal (24)

The RJ12 socket of the RS485-interface has the following pin assignment:

Pin No.	Terminal	Signal
1	c	Signal Ground
2	a	Data a
3	b	Data b
4	b	Data b
5	a	Data a
6	c	Signal Ground

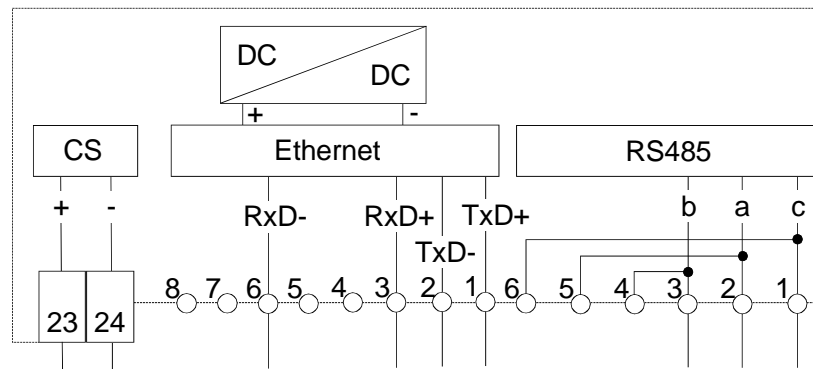

Fig. 3.7 Connection diagram communication unit CU-E22

### 3.3 Faceplate

The faceplate of the communication unit CU-E2x has the following appearance depending on version:

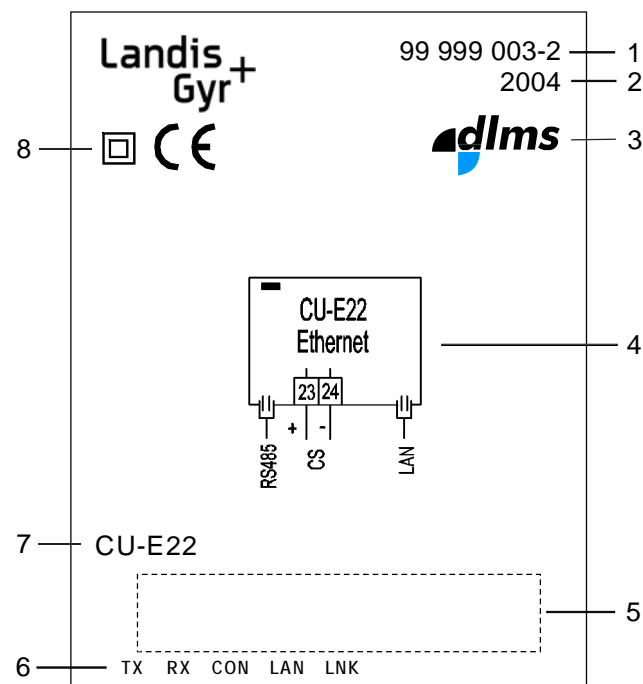

Fig. 3.8 Faceplate of the communication unit CU-E2x (example CU-E22)

- 1 Serial number
- 2 Year of construction
- 3 dlms symbol depending on parameterization
- 4 Diagram
- 5 Ownership designation and bar code
- 6 Designation of transmit/receive LEDs
- 7 Type designation
- 8 Insulation class and CE sign

The faceplate may contain other country-specific data, e.g. warnings, etc.

### 3.4 LEDs

The five LEDs TX, RX, CON, LAN and LNK designated on the face plate are fitted on the circuit cards and can be seen through the transparent strip below the face plate. Their function is described in chapter 5 "Operation".

## 4 Installation/De-installation

### 4.1 Fitting in Meter



#### No voltage to meter when fitting

In order to avoid hazardous electric shocks, ensure there is no voltage applied to the meter when fitting the communication unit. Contact with live parts is dangerous to life. Disconnect the meter from the power supply as described in the meter user manual.

Fit the communication unit in the meter as follows:

1. Ensure that no voltage is applied to the meter.
2. Remove the utility seals on the front door and terminal cover.
3. Open the front door and remove the terminal cover.

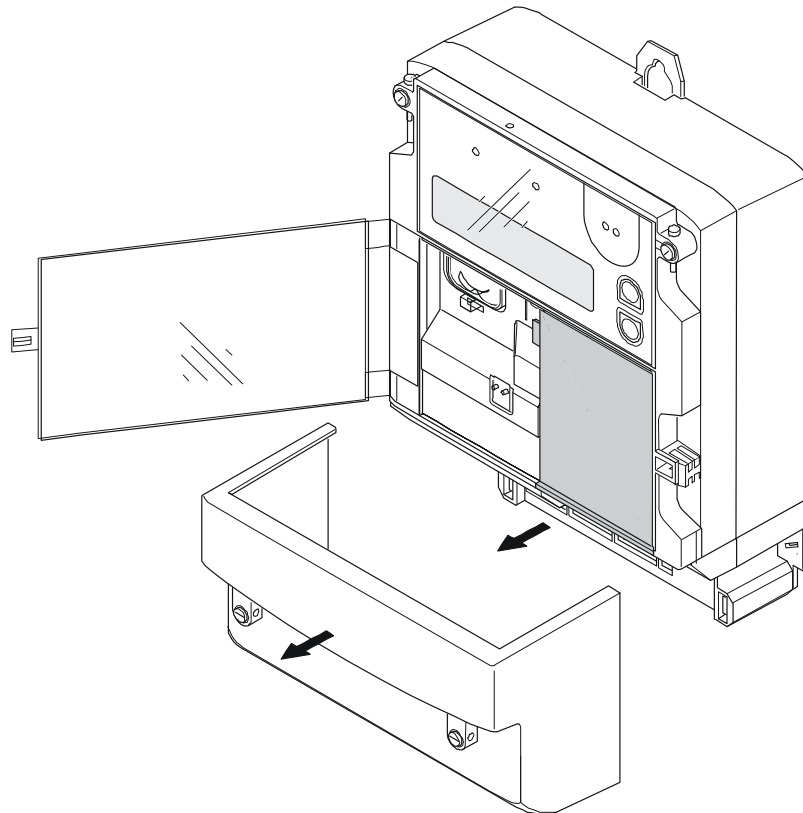

Fig. 4.1 Preparing the meter for fitting the communication unit

4. Remove the built-in "dummy" communication unit.
5. Insert the communication unit carefully at the place provided in the meter. Ensure correct fitting of the connector.

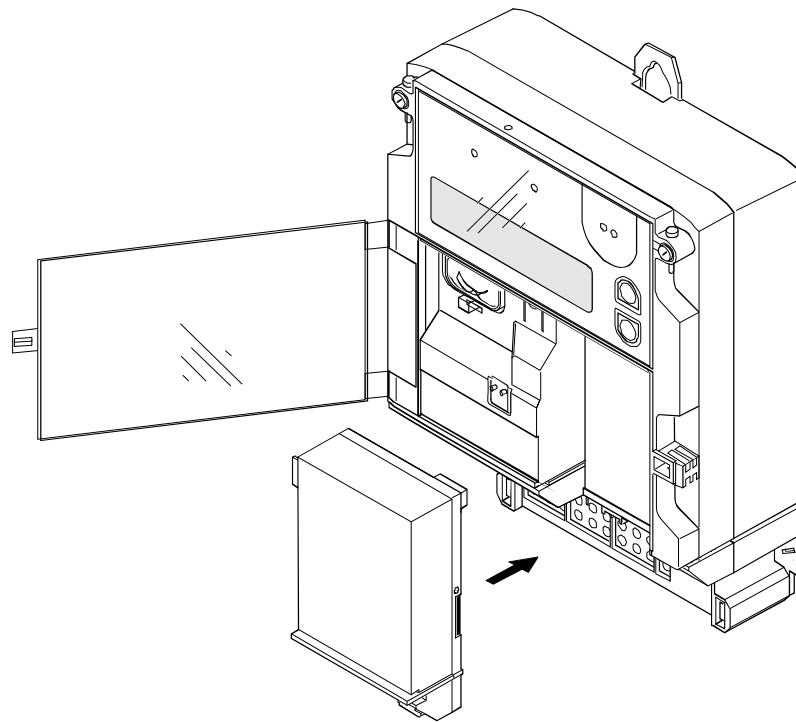

Fig. 4.2 Fitting communication unit in meter

6. Close and seal the front door.

## 4.2 Fitting in CU-Adapter CU-ADP1



### **No voltage to CU-adapter when inserting communication unit**

There must be no voltage applied to the CU-adapter when the communication unit is inserted. Contact with live parts is dangerous to life. If necessary, disconnect the CU-adapter from the power supply as described in the CU-ADP user manual.

Fit the communication unit CU-E22 in the CU-adapter CU-ADP1 as follows:

1. Remove the utility seals on the front cover and on the terminal cover.
2. Remove the front cover and the terminal cover.

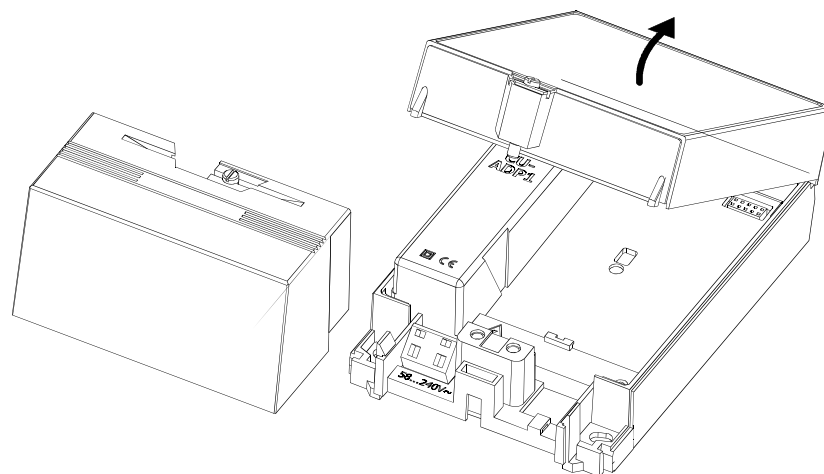

Fig. 4.3 Preparing the CU-adapter CU-ADP1 for fitting the communication unit

3. Insert the communication unit carefully at the position provided in the CU-adapter by first moving this forwards under the cam and then pressing down at the rear. Ensure the correct fit of the plug. The front cover should only be replaced after connecting.

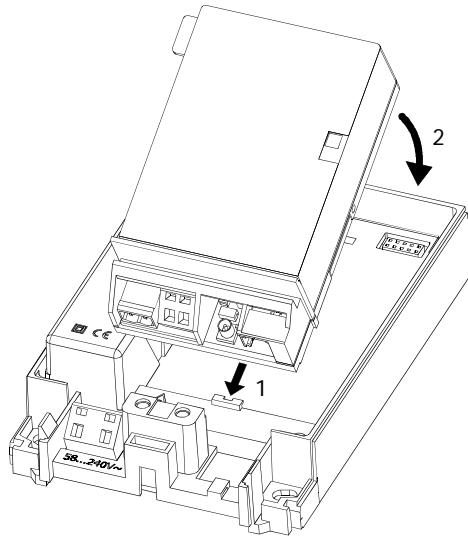

Fig. 4.4 Fitting communication unit in CU-adapter CU-ADP1

4. Connect the communication unit to the meter (via RS485 or CS interface) and the adapter to mains and mount the front cover, see User Manual of the adapter: H 71 0200 0323 en.

## 4.3 Connecting the Communication Unit

### 4.3.1 Connecting the Ethernet Interface

Insert the connecting cable with the RJ45 connector in the right socket labelled Ethernet until the connector can be heard to engage. Connect the other end of the cable to the LAN.

### 4.3.2 Connecting the CS-Interface

Connect the CS-interface of communication unit CU-E22 according to the connection diagram as follows:

1. Shorten the connecting wires to the required length and strip them for approx. 4 mm (wires and strands up to 2.5 mm<sup>2</sup> can be connected).
2. If stranded wire is used as phase connection line, it has to be provided with ferrules for connection.
3. Connect the connecting wires to the screwless spring-loaded terminals (the terminals are numbered as shown on the connection diagram):
  - Insert a size 1 screwdriver in the upper opening and insert it turning slightly upwards (Fig. 4.5 A).
  - Now place the stripped connecting wire in the lower opening and hold it there securely (Fig. 4.5 B).
  - Withdraw the screwdriver. The connecting wire is then firmly fixed (Fig. 4.5 C).

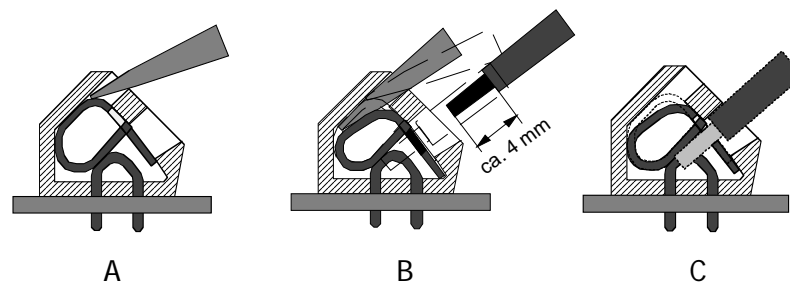

Fig. 4.5 Connection in screwless spring-loaded terminals



#### **Bare end of connecting wire must not be too long**

The insulation of the connecting wire must extend as far as the terminal indentation, i.e. there must be no further bare part of the connecting wire visible above the terminal edge (as shown in Fig. 4.5 C). Touching live parts is dangerous to life. The stripped part of the connecting wire should be shortened if necessary.



#### **Only one wire or ferrule per terminal**

Only one wire or ferrule with strand(s) may be connected in screwless spring-loaded terminals. The terminal could be damaged or the contact could not properly made.

If a connecting wire must be disconnected again for any reason, this is performed in the reverse sequence:

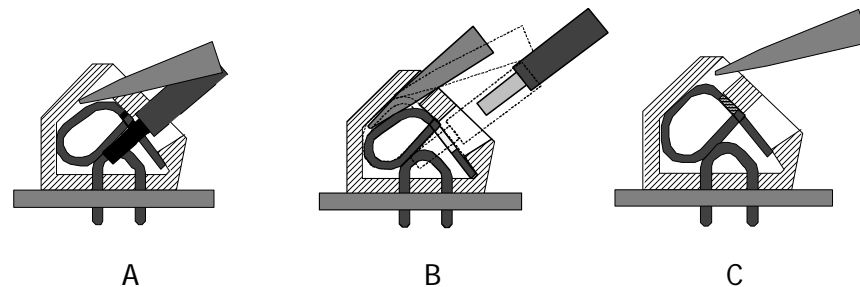

Fig. 4.6 Releasing connection from spring-loaded terminal



#### **Damage to terminals**

Never withdraw connecting wires with the terminal closed, since this could damage the terminal.



### 4.3.3 Connecting the RS485-Interface

Insert the connecting cable with the RJ12 connector in the right socket labelled RS485 until the connector engages. Connect the other end of the cable to the nearest unit of the RS485 multiple connection.

If its RS485-interface is provided with two internally looped RJ12 sockets (e.g. CU-B2), the other end of the cable can also be provided with an RJ12 plug. If, however, only one RJ12 socket is present on the nearest unit (e.g. CU-E22) the loop for the RS485-interface must be formed with a T-piece outside the unit.

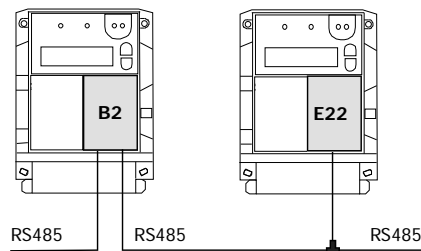

#### External wiring of RS485

In order to function correctly, all 3 wires (data a, data b and Common GND) must be connected. RS485 operation with only 2 wires (without Common GND) is forbidden as the RS485 interface may not function correctly or be damaged.

### 4.3.4 Final Operations

If the communication unit is fitted in a meter, replace the terminal cover and seal with a utility seal.

If the communication unit is fitted in a CU adapter, replace the front cover and terminal cover and seal both with utility seals.

## 4.4 Commissioning and Functional Check

After switching on the mains voltage, LEDs TX and RX flicker briefly. The communication unit CU-E2x is then ready for operation.

When the Ethernet connection is made, the LED LNK lights. A remote read-out of the meter data via the LAN should be performed as a functional check.

If a multiple connection to further appliances is present, check their function.

## 4.5 Removal/Exchange of Communication Unit

The communication unit is exchanged or removed from the meter in reverse order of the installation (see sections 4.1 and 4.2).

## 5 Operation

The communication unit CU-E2x has no control elements. To display communication processes it has five LEDs, which are visible through the transparent strip below the faceplate.

### LEDs

Functions of the five LEDs during normal operation:

- **CON:** This **green LED** is continuously lit if there is a connection between the communication unit and the central station. Data exchange can take place.
- **RX:** This **yellow LED** indicates the reception of characters via the Ethernet or the RS485 interface. If this LED is flashing, it indicates reception of the "Ring" function.
- **TX:** This **yellow LED** indicates the transmission of characters via the Ethernet or the RS485 interface.
- **LAN:** This **yellow LED** lights when transmitting or receiving frames and on detection of data collisions.
- **LNK:** This **green LED** lights while valid link pulses are detected, i.e. when the Ethernet connection is made. The LED is off outside the time window parameterized. It flashes until connection is made.

## 6 Service

### 6.1 Troubleshooting

The following points should first be checked with functional disturbances in the modem connection or the interfaces:

1. Is the mains voltage present (meter liquid crystal display legible, green LED on CU-adapter lights)?
2. Is the maximum permissible ambient temperature not exceeded?
3. Are there any changes or damage visible in the installation?

If none of the points listed is the cause of the fault, the communication unit should be removed and sent to the responsible service and repair centre.

### 6.2 Repairing the Communication Unit

Communication units must only be repaired by an authorised service and repair centre (or by the manufacturer).



#### **Meter operation only with communication unit or "dummy"**

For safety reasons the meter must not be operated without communication unit or a "dummy" communication unit.

---

Adopt the following procedure if a repair is necessary to the communication unit:

1. If installed, remove the communication unit and fit a replacement communication unit. If no spare communication unit is available, a "dummy" unit must be used.
2. Describe the error found as exactly as possible and state the name and telephone number of the person responsible in case of inquiries.
3. Pack the communication unit to ensure it can suffer no further damage during transport. Preferably use the original packing if available. Do not enclose any loose components.
4. Send the communication unit to the responsible service and repair centre.

## 7 Maintenance

The communication unit CU-E2x requires no maintenance.

---



**Never use running water for cleaning**

The communication units must not be cleaned with running water or with high pressure devices. Water penetrating can cause short-circuits or damage electronic components.

---

## 8 Disposal

Based on the data specified in environmental certificate ISO 14001, the components used in the communication units are largely separable and can therefore be taken to the relevant disposal or recycling point.



### Observing local regulations

Observe the local disposal and environmental protection regulations for the disposal of the communication units.

---

Components	Disposal
Printed circuit boards	Electronic waste: disposal according to local regulations.
Metal parts	Sorted and taken to collective materials disposal point.
Plastic components	Sorted and taken to recycling (regranulation) plant or if no other possibility to refuse incineration.

## 9 Index

About this document.....	3	Installation .....	13
Characteristics .....	5	Interface connections .....	10
Commissioning .....	17	LED.....	18
Connecting		LEDs.....	12
CS interface .....	15	Maintenance .....	20
Ethernet interface.....	15	Mechanical construction .....	9
RS485 interface .....	17	Operation.....	18
Connection diagram		Pin numbering of RJ12 socket.....	10
CU-E20 .....	11	Pin numbering of RJ45 socket.....	10
CU-E22 .....	12	Qualifications .....	7
Connections.....	10	Releasing connection from spring-loaded terminal.....	16
CU-E20 .....	10	Removal of communication unit.....	17
CU-E22 .....	11	Repairing the communication unit .....	19
CS interface.....	6	Responsibilities.....	7
CU adapter CU-ADP1 .....	14	RJ12 socket pin numbering .....	10
De-installation .....	13	RJ45 socket pin numbering .....	10
Description of unit.....	5	RS485 interface .....	6
Disposal.....	21	Safety .....	7
Electronic waste .....	21	Scope of application .....	5
Ethernet interface .....	6	Seals.....	9
Faceplate.....	12	Service.....	19
Fitting		Training.....	7
in CU adapter.....	14	Troubleshooting.....	19
in meter .....	13	Type designation .....	5
Functional check.....	17	Versions.....	5
Functions of LEDs .....	18		